

STATE SUBDIVISION-AMENDED PINECREST ADDITION

A PORTION OF SECTION 32, TOWNSHIP 19 NORTH, RANGE 3 EAST,
BOISE MERIDIAN, VALLEY COUNTY, IDAHO

PLAT BOOK 13 PAGE 11

INST. NO. _____

CCR's 381830+
381831

Instrument # 381833
VALLEY COUNTY, CASCADE, IDAHO
11-14-2013 02:49:02 No. of Pages: 6
Recorded for : DEPARTMENT OF LANDS
DOUGLAS A. MILLER Fee: 0.00
Ex-Officio Recorder Deputy *Sperrin*
Index to: PLAT

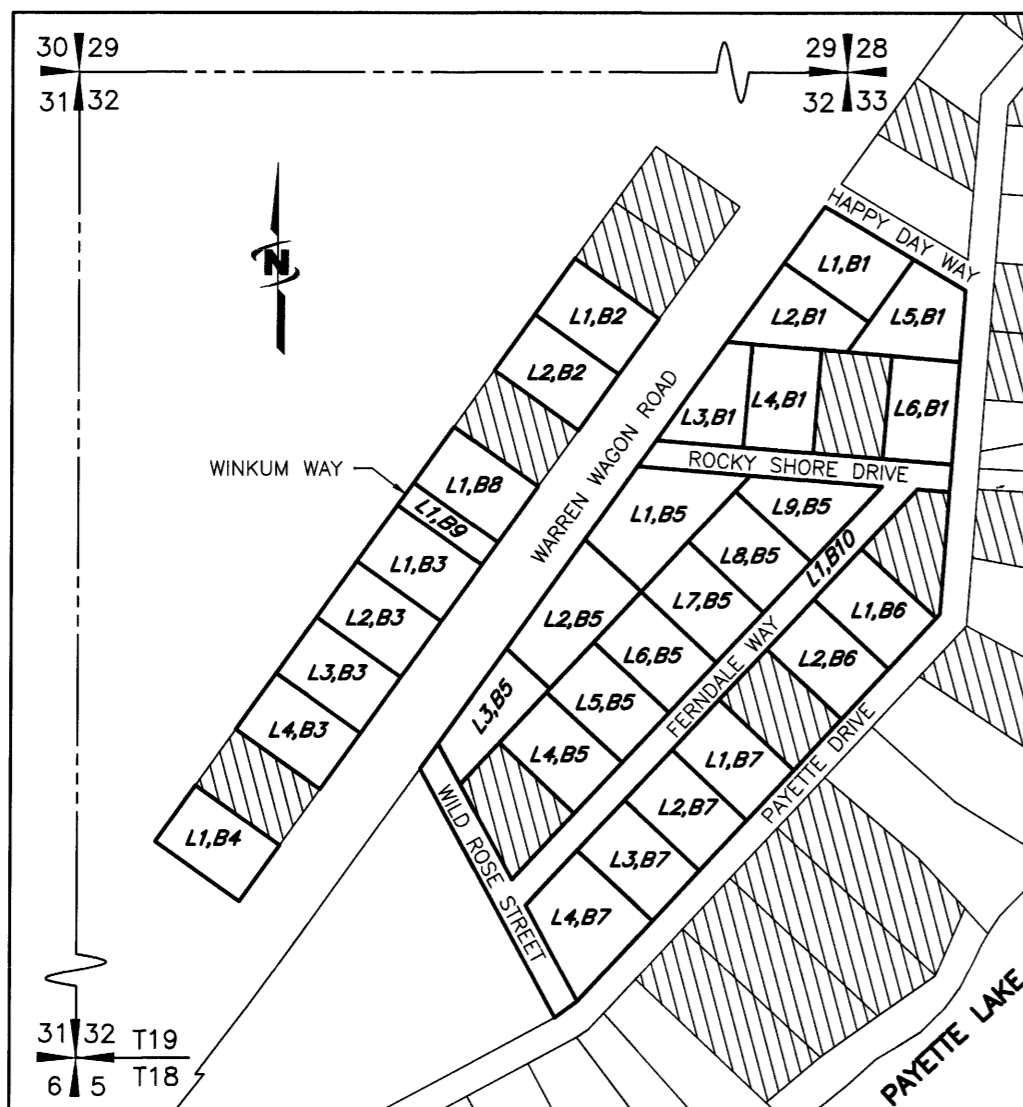
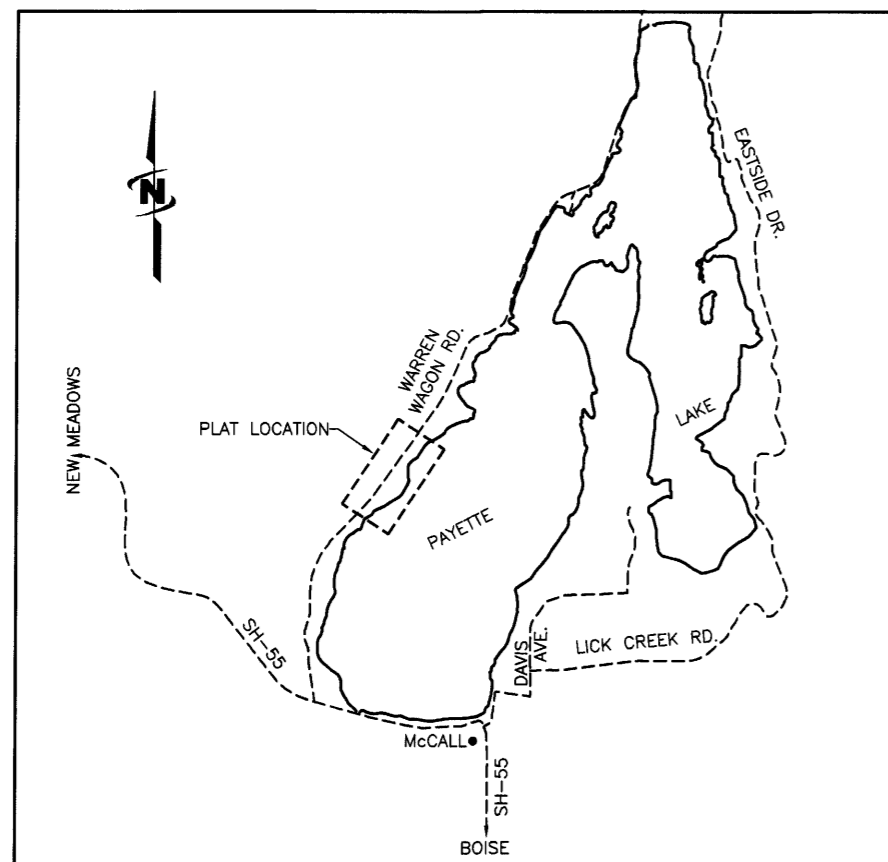

TITLE

WHEN IDAHO BECAME A STATE IN 1890, THE FEDERAL GOVERNMENT ENDOWED (GRANTED) LANDS TO IDAHO ON THE CONDITION THEY PRODUCE MAXIMUM LONG-TERM FINANCIAL RETURNS FOR PUBLIC SCHOOLS AND OTHER BENEFICIARIES. IDAHO NOW HAS OVER 2 MILLION ACRES OF ENDOWMENT LANDS, HELD IN TRUST, PROVIDING FINANCIAL SUPPORT TO PUBLIC SCHOOLS AND OTHER INSTITUTIONS. THE IDAHO DEPARTMENT OF LANDS MANAGES THIS TRUST UNDER THE GOVERNANCE OF THE IDAHO BOARD OF LAND COMMISSIONERS. THE LAND BOARD, ACTING IN THE CAPACITY OF TRUSTEE ON BEHALF OF THE BENEFICIARY SCHOOLS AND OTHER INSTITUTIONS, WAS GIVEN RESPONSIBILITIES UNDER ARTICLE IX, SECTION 8 OF THE IDAHO CONSTITUTION (AS AMENDED) TO MANAGE LANDS IN SUCH A MANNER AS WILL SECURE THE MAXIMUM LONG-TERM FINANCIAL RETURN TO THE INSTITUTION TO WHICH GRANTED. THE LEASING OF ENDOWMENT TRUST LAND FOR USE AS RECREATIONAL COTTAGE SITES BEGAN IN THE EARLY 1930'S AND HAS CONTINUED SINCE ITS INCEPTION. THE CONFIGURATION OF THE LEASED COTTAGE SITES HAS OCCURRED IN AN ORGANIC NATURE OVER A PERIOD OF APPROXIMATELY 80+ YEARS. DUE TO THE NECESSITY BASED STYLE OF DEVELOPMENT AND THE TIME LINE OF THOSE DEVELOPMENTS, THE EXISTING NEIGHBORHOOD AND APPURTENANCES WOULD NOT LIKELY MEET CURRENT LOCAL (COUNTY) DEVELOPMENT STANDARDS.

ADJACENT ENDOWMENT TRUST LANDS

UNLESS EXPRESSLY PROVIDED OTHERWISE, THIS PLAT APPLIES ONLY TO THE ENDOWMENT TRUST LANDS SPECIFICALLY IDENTIFIED ON THE PLAT AND DOES NOT ENCUMBER IN ANY MANNER OR GRANT RIGHTS OF USE TO ANY OTHER ENDOWMENT LANDS. ENDOWMENT LANDS ARE NOT MANAGED FOR THE PUBLIC AT LARGE AND SHALL NOT BE CONSIDERED "PUBLIC LANDS" OR "OPEN SPACE," EITHER SPECIFICALLY OR IN A GENERIC SENSE. ENDOWMENT TRUST LANDS ARE WORKING LANDS PRODUCING REVENUE FOR THE BENEFICIARY INSTITUTIONS. THE IDAHO DEPARTMENT OF LANDS SHALL BE CONTACTED WITH ANY QUESTIONS PERTAINING TO THE ENDOWMENT TRUST LANDS.

ENCROACHMENT PERMITS

AN ENCROACHMENT PERMIT FROM IDAHO DEPARTMENT OF LANDS IS REQUIRED FOR AN ENCROACHMENT UPON THE BED OF NAVIGABLE WATERS.

DOMESTIC WATER

THE STATE MAKES NO REPRESENTATION THAT DOMESTIC WATER SERVICE FOR LOTS EXISTS. THE OWNER WILL BE RESPONSIBLE FOR DOMESTIC WATER.

SANITARY SEWER

THE STATE MAKES NO REPRESENTATION THAT SANITARY SEWER SERVICE FOR THE LOTS EXISTS. IF IT EXISTS, IT IS PROVIDED BY SEPTIC SYSTEMS OR OTHER SYSTEMS THAT MAY NOT COMPLY WITH APPLICABLE FEDERAL, STATE, AND LOCAL LAWS, RULES AND REGULATIONS. ANY FUTURE MODIFICATIONS AND/OR ADDITIONS TO EXISTING SEPTIC SYSTEMS SHALL COMPLY WITH ALL APPLICABLE FEDERAL, STATE, AND LOCAL LAWS, RULES, AND REGULATIONS, AND THE OWNER SHALL PROCURE AT ITS OWN EXPENSE ALL LICENSES AND PERMITS REQUIRED BY SUCH LAWS, RULES, AND REGULATIONS.

SINGLE-FAMILY RESIDENTIAL USE

THE LOTS SHALL BE USED ONLY FOR SINGLE-FAMILY RESIDENCE. NO MORE THAN ONE (1) SINGLE-FAMILY DWELLING SHALL BE ALLOWED ON ANY LOT.

MOBILE HOMES

MOBILE HOMES SHALL NOT BE PLACED ON THE PROPERTY.

MANUFACTURED OR MODULAR HOUSING

MANUFACTURED OR MODULAR HOMES THAT COMPLY WITH ALL APPLICABLE BUILDING CODES, MEET APPLICABLE SNOW LOAD REQUIREMENTS, AND ARE INSTALLED ON A PERMANENT FOUNDATION SHALL BE ALLOWED.

FIRE HAZARDS

LOTS SHALL BE MAINTAINED TO REDUCE FIRE HAZARDS BY THE ELIMINATION OF FINE FUELS AND DEAD MATERIAL ON THE LOT TO PROVIDE A NATURAL BUT MANAGED APPEARANCE.

CONVEYANCE TO ASSOCIATION

THE STATE WILL CONVEY BY QUITCLAIM DEED THE FOLLOWING LOTS; AMENDED CEDAR KNOLL ACRES LOT 1-BLOCK 10; AMENDED PINECREST ADDITION LOT 1-BLOCK 9 AND LOT 1-BLOCK 10; SOUTHWEST PAYETTE COTTAGE SITES LOT 1-BLOCK 28; LOT 1-BLOCK 29; LOT 1-BLOCK 30; LOT 1-BLOCK 31; LOT 1-BLOCK 2; LOT 1-BLOCK 32; LOT 1-BLOCK 4; LOT 1-BLOCK 7; LOT 1-BLOCK 8; LOT 1-BLOCK 11; LOT 1-BLOCK 13; LOT 4-BLOCK 15; LOT 3-BLOCK 20; AND LOT 2-BLOCK 24 AS COMMON AREAS AND ROADS SHOWN ON THIS PLAT UPON FORMATION OF AN ASSOCIATION OF LESSEES AND OWNERS OF LOTS WITHIN THE SOUTHWEST PAYETTE COTTAGE SITES, AMENDED PINECREST ADDITION AND AMENDED CEDAR KNOLL ACRES SUBDIVISIONS, PURSUANT TO THE BYLAWS TO BE RECORDED IN VALLEY COUNTY, IDAHO.

COMMON AREA/ROAD/STREET/LOT MAINTENANCE, CONSTRUCTION AND REPAIR

UPON CONVEYANCE OF THE LOTS REFERENCED IN THE "CONVEYANCE TO ASSOCIATION" PARAGRAPH, THE ASSOCIATION WILL BE RESPONSIBLE FOR ALL MANAGEMENT, CONTROL, MAINTENANCE, CONSTRUCTION AND REPAIR OF THESE ROAD OR COMMON AREA LOTS. THE ASSOCIATION SHALL HAVE NO OBLIGATION TO MAINTAIN ANY RESIDENTIAL LOT OR IMPROVEMENTS ON ANY RESIDENTIAL LOT.

PERMITS REQUIRED

THE STATE MAKES NO REPRESENTATION THAT ANY PERMITS MAY BE OBTAINED FOR THE LOTS OR THAT EXISTING STRUCTURES ARE PERMITTED OR WILL BE PERMITTED. EACH OWNER SHALL COMPLY WITH ALL APPLICABLE FEDERAL, STATE, AND LOCAL LAWS, RULES, AND REGULATIONS AND PROCURE AT ITS OWN EXPENSE ALL LICENSES AND PERMITS REQUIRED BY SUCH LAWS, RULES, AND REGULATIONS RELATED TO THE USE OF THE LOTS.

ACCESS

EXISTING WARREN WAGON ROAD, HAPPY DAY WAY, ROCKY SHORE DRIVE, FERNDALE WAY, WINKUM WAY AND WILD ROSE STREET AS SHOWN HEREON.

EXISTING UTILITIES

UTILITIES SUCH AS WATER, SEWER (INCLUDING: DRAINFIELD LINES, EFFLUENT LINES, SEPTIC TANKS, CLEAN OUTS, ETC.), POWER, TELEPHONE AND GAS ARE INSTALLED AND EXISTING WITHIN THE LOTS SHOWN HEREON. IN SOME CASES, THESE UTILITIES TRAVERSE ACROSS SEVERAL ADJACENT LOTS DUE TO THE CONVENIENCE OF INSTALLATION AND MAINTENANCE. EACH LOT OWNER SHALL HAVE THE RIGHT TO ACCESS AND MAINTAIN THE UTILITIES THAT SERVE THEIR LOT. IT SHALL BE THE RESPONSIBILITY OF THE LOT OWNER(S) PERFORMING THE MAINTENANCE TO RETURN ANY DISTURBED LAND, LANDSCAPING, FENCES, ROADWAYS, ETC. TO THEIR PRE-MAINTENANCE CONDITION. IF AT THE TIME OF MAINTENANCE IT IS MONETARILY EQUITABLE AND REASONABLE TO DO SO, THE UTILITIES SHALL BE RE-ROUTED TO BE CONTAINED WITHIN THE SERVED LOT VIA THE EXISTING EASEMENT OR ALTERNATIVE EASEMENT PROCURED BY THE LOT OWNER.

DISCLAIMER

THE LOTS ARE PLATTED IN AN "AS IS" CONDITION. THE STATE MAKES NO REPRESENTATION OR WARRANTY WITH RESPECT TO THE LOTS OR CONCERNING THE SUITABILITY OF THE LOTS FOR THE USES INTENDED BY AN OWNER.

Sermy Russell
Digitally signed on:
Nov 05, 2013

STATE SUBDIVISION-AMENDED PINECREST ADDITION			
A PORTION OF SECTION 32, TOWNSHIP 19 NORTH, RANGE 3 EAST, BOISE MERIDIAN, VALLEY COUNTY, IDAHO			
J-U-B ENGINEERS, INC.		J-U-B ENGINEERS, Inc.	
7825 Meadowlark Way Coeur d'Alene, Idaho 83815 Phone: 208.762.8787		7825 Meadowlark Way Coeur d'Alene, Idaho 83815 Phone: 208.762.8787	
DWG NAME: 20-11-036_Amended Pinecrest Addition_cover	DR. DFG	CH. GJR / DRB	SHEET 1 OF 6
SCALE: NONE	DATE: November 2013	PROJ. NO.: 20-11-036	

STATE SUBDIVISION-AMENDED PINECREST ADDITION

A PORTION OF SECTION 32, TOWNSHIP 19 NORTH, RANGE 3 EAST,
BOISE MERIDIAN, VALLEY COUNTY, IDAHO

PLAT BOOK 13 PAGE 11
INST. NO. _____

CERTIFICATE OF STATE

BE IT KNOWN BY THESE PRESENTS: THAT THE STATE OF IDAHO, THE RECORD OWNER OF THE REAL PROPERTY SHOWN HEREON, UNDER ITS AUTHORITY SET FORTH IN IDAHO CODE HAS CAUSED THE SAME TO BE SURVEYED AND DIVIDED INTO LOTS AND BLOCKS AS PLATTED HEREON, TO BE KNOWN AS **STATE SUBDIVISION - AMENDED PINECREST ADDITION**, BEING BLOCKS 2, 3, 4, 5, AND 6 OF PINECREST ADDITION TO PAYETTE LAKE COTTAGE SITES, ACCORDING TO THE PLAT THEREOF RECORDED IN BOOK 1 OF PLATS, PAGE 10, RECORDS OF VALLEY COUNTY, IDAHO, BEING SITUATED IN A PORTION OF SECTION 32, TOWNSHIP 19 NORTH, RANGE 3 EAST, BOISE MERIDIAN, VALLEY COUNTY, IDAHO, FURTHER DESCRIBED AS FOLLOWS:

BEGINNING AT THE WESTERNMOST CORNER OF BLOCK 6 AS SHOWN ON SAID PLAT; THENCE NORTH 35°32'17" EAST, ALONG THE WESTERLY BOUNDARY OF SAID BLOCK 6, 399.91 FEET TO THE NORTHWEST CORNER OF LOT 4 OF SAID BLOCK 6;
THENCE SOUTH 54°29'32" EAST, ALONG THE NORTHERLY LINE OF SAID LOT 4, 149.82 FEET TO THE WESTERLY RIGHT-OF-WAY LINE OF WARREN WAGON ROAD AS SHOWN ON SAID PLAT OF PINECREST ADDITION TO PAYETTE LAKE COTTAGE SITES;
THENCE SOUTH 71°16'55" EAST, 104.47 FEET TO THE EASTERLY RIGHT-OF-WAY LINE OF WARREN WAGON ROAD AS SHOWN ON SAID PLAT OF PINECREST ADDITION TO PAYETTE LAKE COTTAGE SITES;
THENCE NORTH 35°31'34" EAST, ALONG SAID RIGHT-OF-WAY LINE OF WARREN WAGON ROAD, 241.05 FEET TO THE SOUTHERLY RIGHT-OF-WAY LINE OF HAPPY DAY WAY AS SHOWN ON SAID PLAT OF PINECREST ADDITION TO PAYETTE LAKE COTTAGE SITES;
THENCE SOUTH 59°06'48" EAST, ALONG SAID RIGHT-OF-WAY LINE OF HAPPY DAY WAY, 237.69 FEET TO THE WESTERLY RIGHT-OF-WAY LINE OF PAYETTE DRIVE AS SHOWN ON SAID PLAT OF PINECREST ADDITION TO PAYETTE LAKE COTTAGE SITES;

THENCE ALONG SAID RIGHT-OF-WAY LINE OF PAYETTE DRIVE THE FOLLOWING TWO (2) COURSES:

1. SOUTH 04°17'03" WEST, 470.67 FEET;
2. SOUTH 42°54'04" WEST, 767.42 FEET TO THE EASTERLY RIGHT-OF-WAY LINE OF WILD ROSE STREET AS SHOWN ON SAID PLAT OF PINECREST ADDITION TO PAYETTE LAKE COTTAGE SITES;

THENCE SOUTH 53°13'28" WEST, 40.42 FEET TO THE WESTERLY RIGHT-OF-WAY LINE OF WILD ROSE STREET AS SHOWN ON SAID PLAT OF PINECREST ADDITION TO PAYETTE LAKE COTTAGE SITES;

THENCE NORTH 28°30'42" WEST, ALONG SAID RIGHT-OF-WAY LINE OF WILD ROSE STREET, 411.79 FEET TO THE EASTERLY RIGHT-OF-WAY OF WARREN WAGON ROAD SHOWN ON SAID PLAT OF PINECREST ADDITION TO PAYETTE LAKE COTTAGE SITES;
THENCE SOUTH 35°31'34" WEST, ALONG SAID RIGHT-OF-WAY LINE OF WARREN WAGON, 307.74 FEET;
THENCE NORTH 55°07'04" WEST, 100.00 FEET TO THE WESTERLY RIGHT-OF-WAY LINE OF WARREN WAGON ROAD SHOWN ON SAID PLAT OF PINECREST ADDITION TO PAYETTE LAKE COTTAGE SITES;
THENCE NORTH 54°28'33" WEST, ALONG THE SOUTHERLY BOUNDARY OF BLOCK 5 AS SHOWN ON SAID PLAT, 149.92 FEET;
THENCE NORTH 35°31'36" EAST, ALONG THE WESTERLY BOUNDARY OF SAID BLOCK 5, 600.16 FEET;
THENCE NORTH 35°32'56" EAST, CONTINUING ALONG SAID BOUNDARY, 40.00 FEET TO THE POINT OF BEGINNING.

EXCEPTING THEREFROM LOT 1, BLOCK 2; LOTS 5 AND 8, BLOCK 3; LOT 2, BLOCK 4; LOT 2, BLOCK 5; LOT 2, BLOCK 6 OF PINECREST ADDITION TO PAYETTE LAKE COTTAGE SITES, ACCORDING TO THE PLAT THEREOF RECORDED IN BOOK 1 OF PLATS, PAGE 10, RECORDS OF VALLEY COUNTY, IDAHO, BEING SITUATED IN A PORTION OF SECTION 32, TOWNSHIP 19 NORTH, RANGE 3 EAST, BOISE MERIDIAN, VALLEY COUNTY, IDAHO.

CONTAINING 11.86 ACRES, MORE OR LESS.

SAID LANDS ARE SUBJECT TO EASEMENTS OF RECORD AND RIGHTS-OF-WAY OF RECORD.

IDAHO STATE BOARD OF LAND COMMISSIONERS APPROVAL

IN WITNESS WHEREOF, THE STATE BOARD OF LAND COMMISSIONERS HAS CAUSED THESE PRESENTS TO BE EXECUTED BY ITS PRESIDENT, THE GOVERNOR OF THE STATE OF IDAHO, AND COUNTERSIGNED BY THE SECRETARY OF THE STATE AND THE DIRECTOR, IDAHO DEPARTMENT OF LANDS.

THE STATE BOARD OF LAND COMMISSIONERS

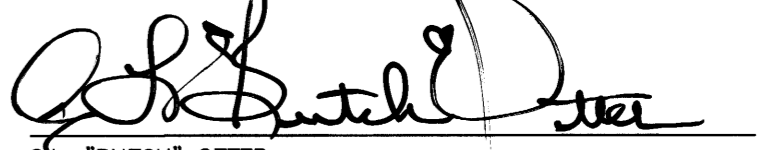
C.L. "BUTCH" OTTER
GOVERNOR OF THE STATE OF IDAHO
PRESIDENT OF THE STATE BOARD OF LAND COMMISSIONERS

COUNTERSIGNED:

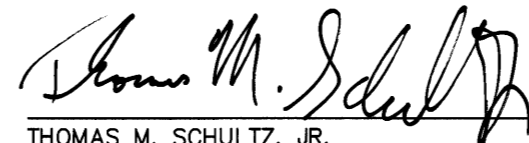

BEN YSURSA
SECRETARY OF STATE



THOMAS M. SCHULTZ, JR.
DIRECTOR, IDAHO DEPARTMENT OF LANDS

THE STATE OF IDAHO)
) SS.
COUNTY OF ADA)

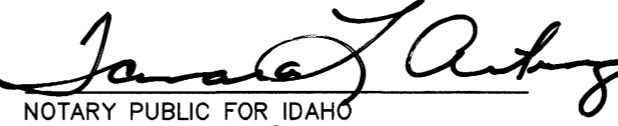
ON THIS DAY 13th DAY OF November, 2013, BEFORE ME, A NOTARY PUBLIC IN AND FOR THE STATE, PERSONALLY APPEARED C.L. "BUTCH" OTTER, KNOWN TO ME TO BE THE GOVERNOR OF THE STATE OF IDAHO AND PRESIDENT OF THE STATE BOARD OF LAND COMMISSIONERS; BEN YSURSA, KNOWN TO ME TO BE THE SECRETARY FOR THE STATE OF IDAHO; AND THOMAS M. SCHULTZ, JR., KNOWN TO ME TO BE THE DIRECTOR OF DEPARTMENT OF LANDS OF THE STATE OF IDAHO, THAT EXECUTED THE SAME INSTRUMENT AND ACKNOWLEDGED TO ME THAT SUCH THE STATE OF IDAHO AND THE STATE BOARD OF LAND COMMISSIONERS EXECUTED THE SAME.

IN WITNESS WHEREOF, I HAVE HEREUNTO SET MY HAND AND SEAL ON THE DAY AND YEAR WRITTEN ABOVE.

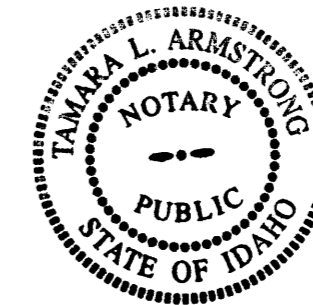
NOTARY PUBLIC FOR IDAHO
RESIDING AT Boise, IDAHO
MY COMMISSION EXPIRES: 12/26/18



VALLEY COUNTY RECORDER

I HEREBY CERTIFY THAT THIS PLAT OF **STATE SUBDIVISION-AMENDED PINECREST ADDITION** WAS FILED FOR RECORD IN THE OFFICE OF THE RECORDER OF VALLEY COUNTY, IDAHO AT THE REQUEST OF _____, THIS _____ DAY OF _____, 2013, AT _____ O'CLOCK _____ M., AND DULY RECORDED IN BOOK _____ OF PLATS, AT PAGES _____ AS INSTRUMENT NUMBER _____.

SURVEYOR'S CERTIFICATE

I, GEREY J. RUSSELL, PROFESSIONAL LAND SURVEYOR NO. 13419 IN THE STATE OF IDAHO, DO HEREBY CERTIFY THAT THIS PLAT OF **STATE SUBDIVISION-AMENDED PINECREST ADDITION** IS BASED ON AN ACTUAL FIELD SURVEY MADE BY ME OR UNDER MY SUPERVISION AND ALL CORNERS AND DIMENSIONS ARE CORRECTLY SHOWN AND THAT SAID PLAT IS STAKED ON THE GROUND AS INDICATED HEREON.

Digitally signed on:
Nov 05, 2013

STATE SUBDIVISION-AMENDED PINECREST ADDITION			
A PORTION OF SECTION 32, TOWNSHIP 19 NORTH, RANGE 3 EAST, BOISE MERIDIAN, VALLEY COUNTY, IDAHO			
		J-U-B ENGINEERS, Inc. 7825 Meadowlark Way Coeur d'Alene, Idaho 83815 Phone: 208.762.8787	
DWG NAME: 20-11-036_Amended Pinecrest Addition_cover			
J-U-B ENGINEERS, INC.		DR. DFG	CH. GJR / DRB SHEET 2 OF 6
SCALE: NONE		DATE: November 2013	PROJ. NO.: 20-11-036

STATE SUBDIVISION-AMENDED PINECREST ADDITION

A PORTION OF SECTION 32, TOWNSHIP 19 NORTH, RANGE 3 EAST,
BOISE MERIDIAN, VALLEY COUNTY, IDAHO

PLAT BOOK 13 PAGE 11

INST. NO. _____

SURVEYORS NOTES

- DIMENSIONS SHOWN ARE TO ACTUAL LOT CORNERS, IN SOME CASES THE FOUND MONUMENT AND RECORD DID NOT MATCH. DETAILS SHOWN REVEAL THAT RELATIONSHIP.
- FERNDALE WAY, ROCKY SHORE DRIVE, AND WILD ROSE STREET ARE PLATTED AS LOT 1, BLOCK 10, HEREON. (1.53 AC±); WINKUM WAY IS PLATTED AS LOT 1, BLOCK 9, HEREON. (0.14 AC±)

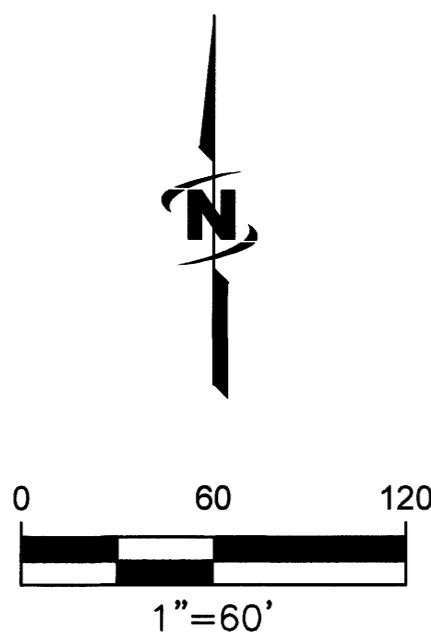

LEGEND

- EXISTING EASEMENT LOCATIONS ARE SHOWN PER EASEMENT LEGAL DESCRIPTION AND/OR THEIR PHYSICAL APPURTENANCES.
- CALCULATED LINE OR MATHEMATICAL TIE LINE
- PRIVATE OWNERSHIP (NOT PART OF THIS SUBDIVISION)
- SECTION CORNER-AS NOTED
- FOUND BRASS CAP
- FOUND ALUMINUM CAP
- FOUND IRON PIPE
- FOUND 5/8" REBAR, NO CAP-UNLESS OTHERWISE NOTED
- FOUND 1/2" REBAR, NO CAP-UNLESS OTHERWISE NOTED
- CALCULATED POINT, NOTHING FOUND OR SET
- SET 5/8" X 30" REBAR WITH YELLOW PLASTIC CAP, MARKED "JUB ENGINEERS PLS 13419"
- P.O.B. POINT OF BEGINNING
- SEE SHEETS 5 AND 6 FOR DETAILS

LINE TABLE		
LINE #	DIRECTION	LENGTH
L1	N76°53'51"E	31.78'
L2	S85°14'35"E	36.76'
L3	S71°16'55"E	41.79'
L4	S71°16'55"E	62.68'

RECORD INFORMATION

- AMENDED PLAT OF STATE LAND PAYETTE LAKE COTTAGE SITES BY GEORGE TUCKER, PE, DATED OCTOBER 15, 1932, BOOK 1 OF PLATS, PAGE 19A, RECORDS OF VALLEY COUNTY.
- PLAT OF PINECREST ADDITION TO PAYETTE LAKE COTTAGE SITES BY VIRGIL JOHNSON, PE 382 AND HORACE PALMER, PE 285, DATED OCTOBER 15, 1947, BOOK 1 OF PLATS, PAGE 10, RECORDS OF VALLEY COUNTY.
- RECORD OF SURVEY BY THOMAS KERR, PLS 998, DATED MARCH 10, 1988, INSTRUMENT NUMBER 160393, RECORDS OF VALLEY COUNTY.
- EASEMENT IN FAVOR OF THE STATE OF IDAHO, DATED JANUARY 9, 1936, FOR HIGHWAY PURPOSES. IDL DOCUMENT NUMBER 444.
- PARTIALLY AMENDED EASEMENT IN FAVOR OF THE PAYETTE LAKES WATER AND SEWER DISTRICT, FOR SEWER LINE, IDL DOCUMENT NUMBER 4905-A.
- EASEMENT IN FAVOR OF WEST COAST POWER COMPANY, DATED JUNE 13, 1941, FOR ELECTRIC SERVICE PURPOSES. IDL DOCUMENT NUMBER 606.
- EASEMENT IN FAVOR OF PAYETTE LAKES WATER AND SEWER DISTRICT, DATED DECEMBER 15, 1983, FOR CONSTRUCTING, USING AND MAINTAINING A BURIED SANITARY SEWER LINE. IDL DOCUMENT NUMBER 5163-A.
- EASEMENT IN FAVOR OF IDAHO POWER COMPANY, DATED JANUARY 28, 1987, FOR CONSTRUCTING, USING, AND MAINTAINING A BURIED POWERLINE, IDL DOCUMENT NUMBER 5294.
- EASEMENT IN FAVOR OF ORVAL CAREY, DATED OCTOBER 30, 1998, FOR CONSTRUCTING, USING, AND MAINTAINING A BURIED WATERLINE AND WELLHEAD, IDL DOCUMENT NUMBER 6139.
- UNITED STATES DEPARTMENT OF AGRICULTURE, BUREAU OF PUBLIC ROADS, PROJECT FHCC-21-A2.B2, ROUTE NO. 21 WARREN WAGON ROAD.
- EASEMENT IN FAVOR OF VALLEY COUNTY, DATED SEPTEMBER 24, 1924, FOR CONSTRUCTING "WARREN WAGON ROAD", IDL DOCUMENT NUMBER 220.
- INVENTORY SURVEY PREPARED BY JUB ENGINEERS, INC., 2011, ON FILE WITH THE IDAHO DEPARTMENT OF LANDS.

Jeremy Russell
Digitally signed on:
Nov 05, 2013

STATE SUBDIVISION-AMENDED PINECREST ADDITION	
A PORTION OF SECTION 32, TOWNSHIP 19 NORTH, RANGE 3 EAST, BOISE MERIDIAN, VALLEY COUNTY, IDAHO	
 J-U-B ENGINEERS, INC.	J-U-B ENGINEERS, Inc. 7825 Meadowlark Way Coeur d'Alene, Idaho 83815 Phone: 208.762.8787
	DWG NAME: 20-11-036_Amended Pinecrest Addition
SCALE: 1"=60'	DR. DFG CH. GJR / DRB SHEET 3 OF 6
DATE: November 2013	PROJ. NO.: 20-11-036

STATE SUBDIVISION-AMENDED PINECREST ADDITION

A PORTION OF SECTION 32, TOWNSHIP 19 NORTH, RANGE 3 EAST,
BOISE MERIDIAN, VALLEY COUNTY, IDAHO

PLAT BOOK 13 PAGE 11
INST. NO. _____

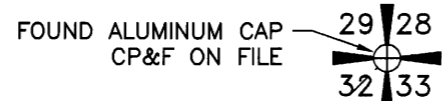
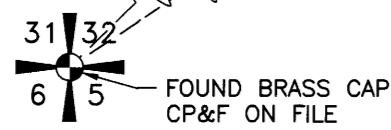
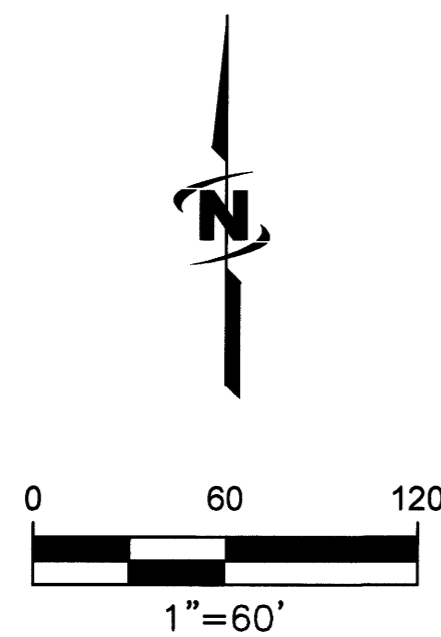

LEGEND

- EXISTING EASEMENT LOCATIONS ARE SHOWN PER EASEMENT LEGAL DESCRIPTION AND/OR THEIR PHYSICAL APPURTENANCES.
- CALCULATED LINE OR MATHEMATICAL TIE LINE
- PRIVATE OWNERSHIP (NOT PART OF THIS SUBDIVISION)
- SECTION CORNER-AS NOTED
- FOUND BRASS CAP
- FOUND ALUMINUM CAP
- FOUND IRON PIPE
- FOUND 5/8" REBAR, NO CAP-UNLESS OTHERWISE NOTED
- FOUND 1/2" REBAR, NO CAP-UNLESS OTHERWISE NOTED
- CALCULATED POINT, NOTHING FOUND OR SET
- SET 5/8" X 30" REBAR WITH YELLOW PLASTIC CAP, MARKED "JUB ENGINEERS PLS 13419"
- P.O.B. POINT OF BEGINNING
- SEE SHEETS 5 AND 6 FOR DETAILS

SURVEYORS NOTES

1. DIMENSIONS SHOWN ARE TO ACTUAL LOT CORNERS, IN SOME CASES THE FOUND MONUMENT AND RECORD DID NOT MATCH. DETAILS SHOWN REVEAL THAT RELATIONSHIP.
2. FERNDALE WAY, ROCKY SHORE DRIVE, AND WILD ROSE STREET ARE PLATTED AS LOT 1, BLOCK 10. HEREON. (1.53 AC±); WINKUM WAY IS PLATTED AS LOT 1, BLOCK 9, HEREON. (0.14 AC±)
3. SEE OTHER SHEETS FOR RECORD INFORMATION.

LINE TABLE		
LINE #	DIRECTION	LENGTH
L5	N35°32'56"E	40.00'
L6	N55°07'04"W	40.00'
L7	N55°07'04"W	60.00'
L8	N43°02'23"E	6.83'
L9	N50°04'41"E	27.18'
L10	S53°13'28"W	40.42'

CURVE TABLE					
CURVE #	LENGTH	RADIUS	DELTA	CHORD BEARING	CHORD LENGTH
C1	1.12'	5669.58'	0°00'41"	N35°31'54"E	1.12'

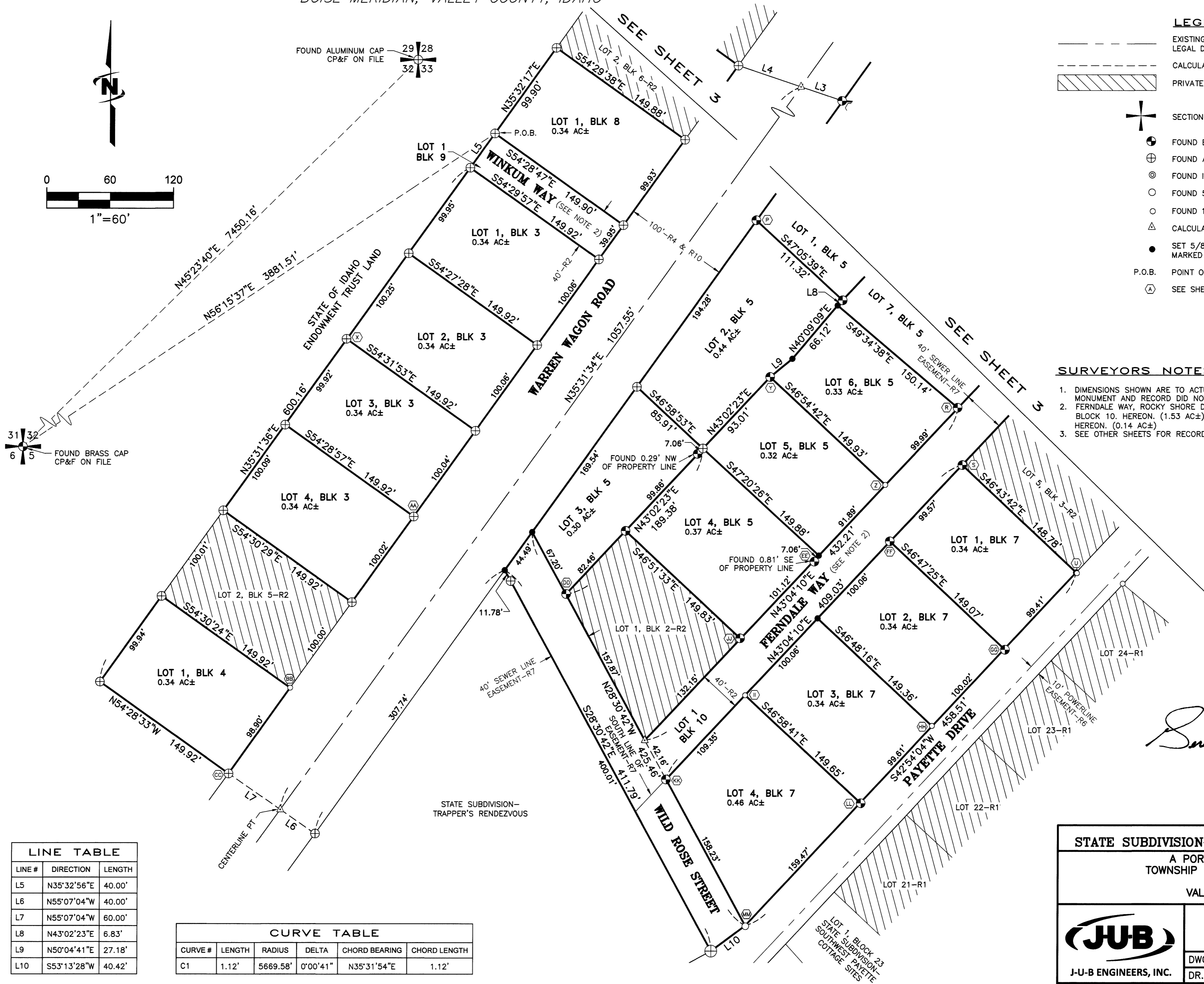

Jeremy Russell
Digitally signed on:
Nov 05, 2013

PROFESSIONAL LAND SURVEYOR
LICENSED
13419
STATE OF IDAHO
GEREMY J. RUSSELL

STATE SUBDIVISION-AMENDED PINECREST ADDITION			
A PORTION OF SECTION 32, TOWNSHIP 19 NORTH, RANGE 3 EAST, BOISE MERIDIAN, VALLEY COUNTY, IDAHO			
 J-U-B ENGINEERS, INC.	J-U-B ENGINEERS, Inc. 7825 Meadowlark Way Coeur d'Alene, Idaho 83815 Phone: 208.762.8787		
	DWG NAME: 20-11-036_Amended Pincrest Addition		
DR. DFG	CH. GJR / DRB	SHEET 4	OF 6
SCALE: 1"=60'	DATE: November 2013	PROJ. NO.: 20-11-036	

STATE SUBDIVISION-AMENDED PINECREST ADDITION

A PORTION OF SECTION 32, TOWNSHIP 19 NORTH, RANGE 3 EAST,
BOISE MERIDIAN, VALLEY COUNTY, IDAHO

PLAT BOOK 13 PAGE 11
INST. NO. _____

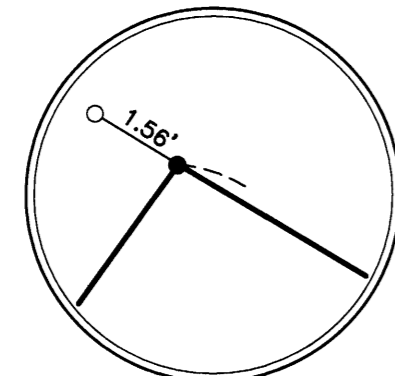

DETAIL A
NOT TO SCALE

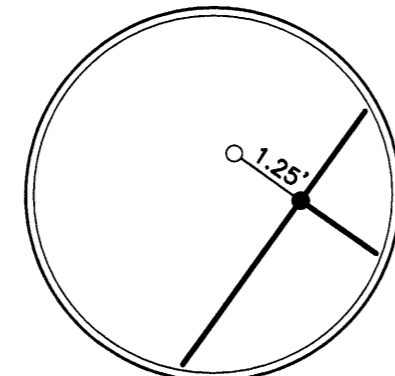

DETAIL B
NOT TO SCALE

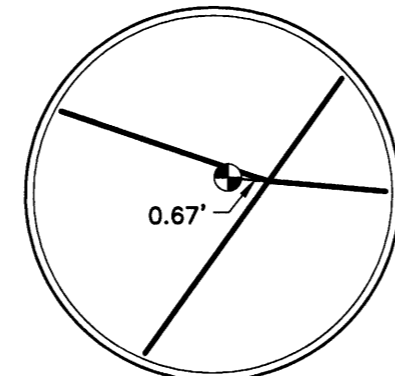

DETAIL C
NOT TO SCALE

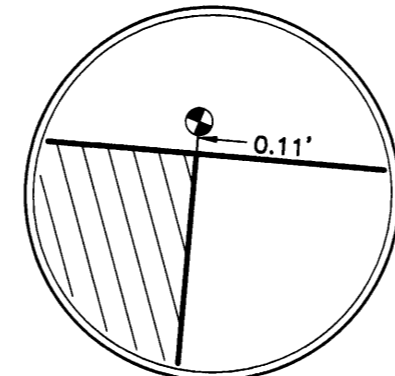

DETAIL D
NOT TO SCALE

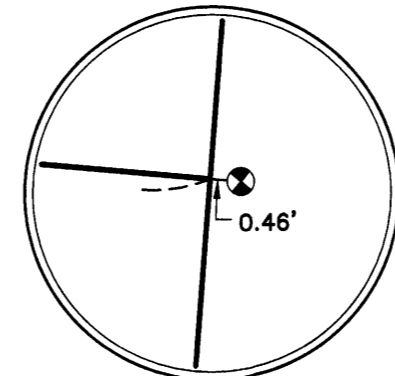

DETAIL E
NOT TO SCALE

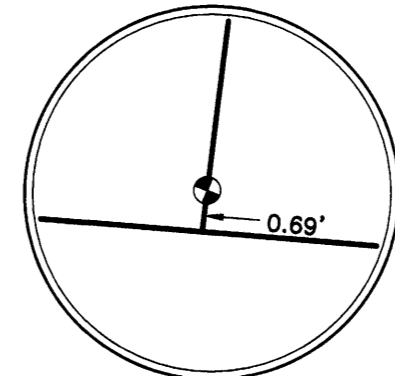

DETAIL F
NOT TO SCALE

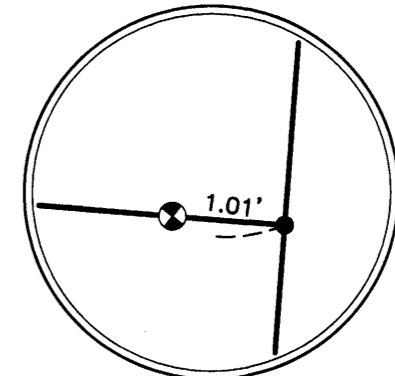

DETAIL G
NOT TO SCALE

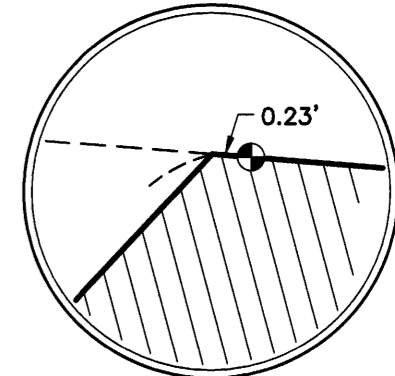

DETAIL H
NOT TO SCALE

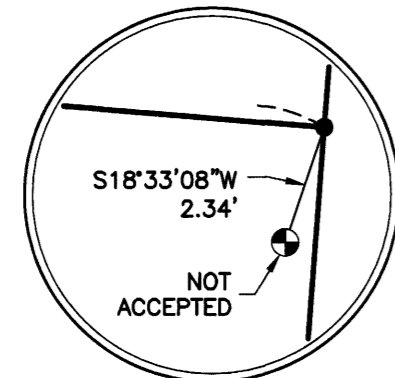

DETAIL I
NOT TO SCALE

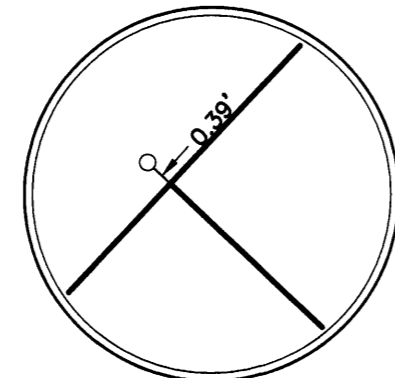

DETAIL J
NOT TO SCALE

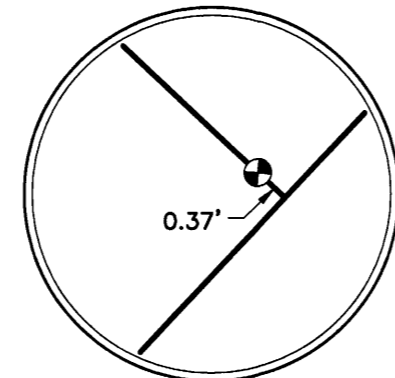

DETAIL K
NOT TO SCALE

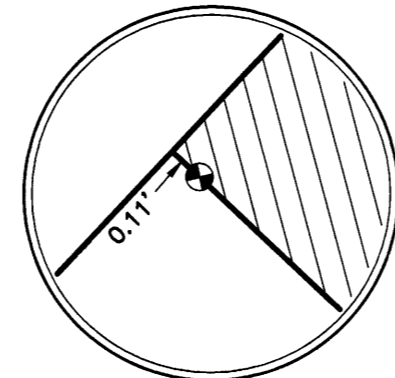

DETAIL L
NOT TO SCALE

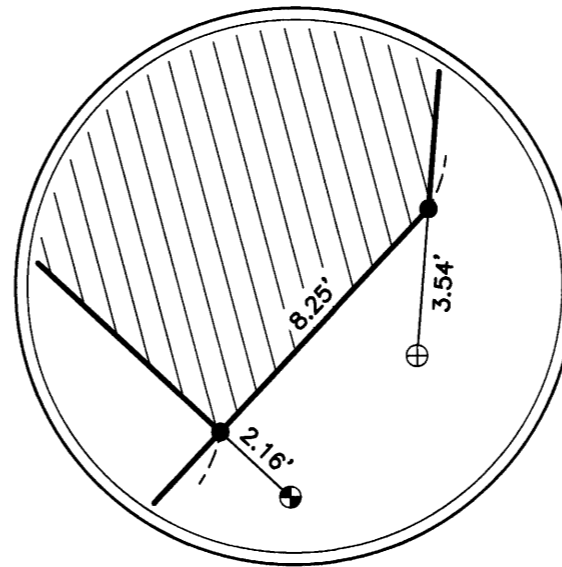

DETAIL M
NOT TO SCALE

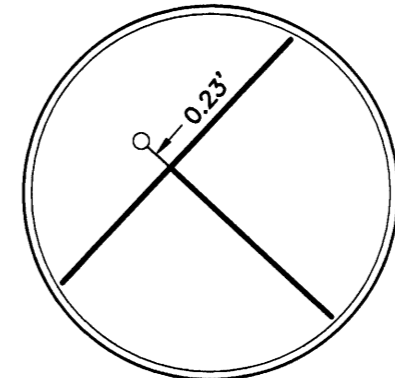

DETAIL N
NOT TO SCALE

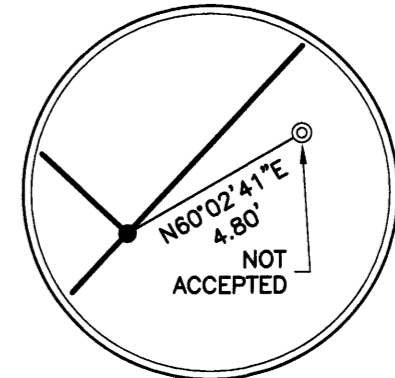

DETAIL O
NOT TO SCALE

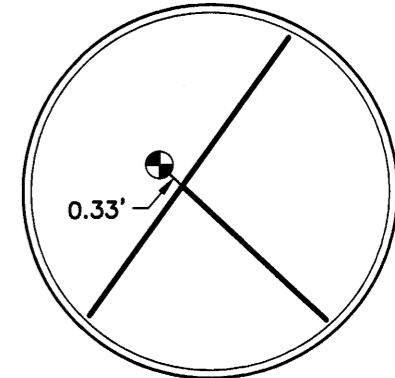

DETAIL P
NOT TO SCALE

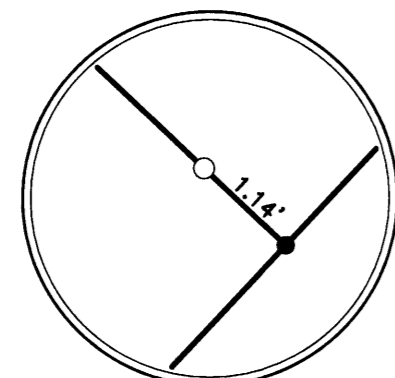

DETAIL Q
NOT TO SCALE

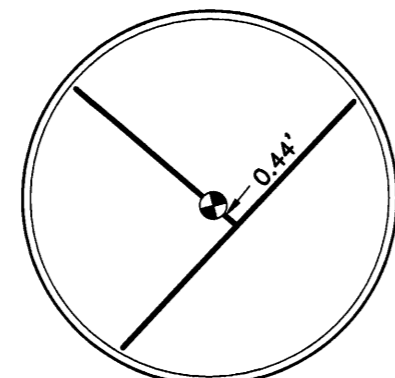

DETAIL R
NOT TO SCALE

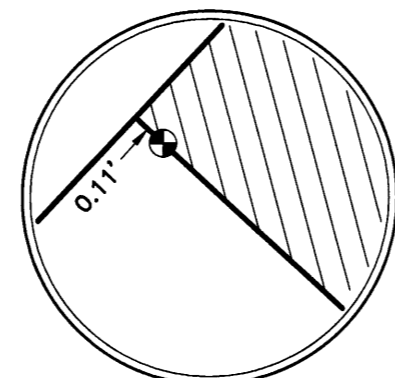

DETAIL S
NOT TO SCALE

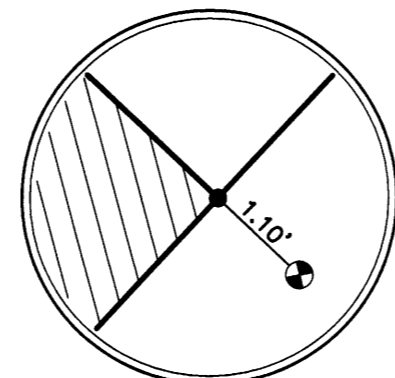

DETAIL T
NOT TO SCALE

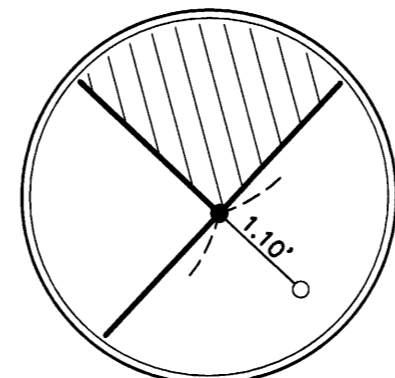

DETAIL U
NOT TO SCALE

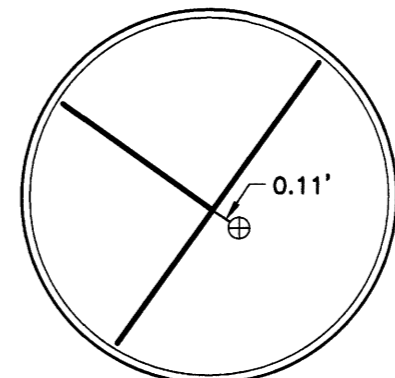

DETAIL V
NOT TO SCALE

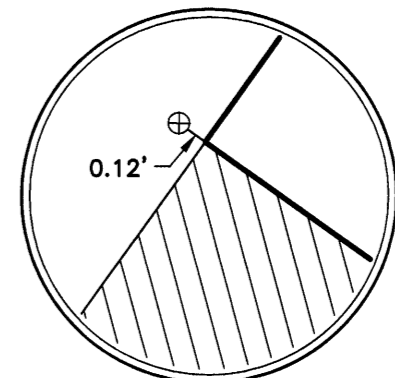

DETAIL W
NOT TO SCALE

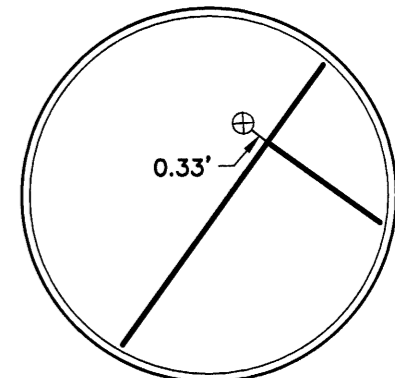

DETAIL X
NOT TO SCALE

Jeremy Russell
Digitally signed on:
Nov 05, 2013

STATE SUBDIVISION-AMENDED PINECREST ADDITION			
A PORTION OF SECTION 32, TOWNSHIP 19 NORTH, RANGE 3 EAST, BOISE MERIDIAN, VALLEY COUNTY, IDAHO			
 J-U-B ENGINEERS, INC.		J-U-B ENGINEERS, Inc. 7825 Meadowlark Way Coeur d'Alene, Idaho 83815 Phone: 208.762.8787	
DWG NAME: 20-11-036_Amended Pinecrest Addition			
DR. DFG	CH. GJR / DRB	SHEET 5	OF 6
SCALE: NONE		DATE: November 2013	
		PROJ. NO.: 20-11-036	

STATE SUBDIVISION—AMENDED PINECREST ADDITION

A PORTION OF SECTION 32, TOWNSHIP 19 NORTH, RANGE 3 EAST,
BOISE MERIDIAN, VALLEY COUNTY, IDAHO

PLAT BOOK 13 PAGE 11

INST. NO. _____

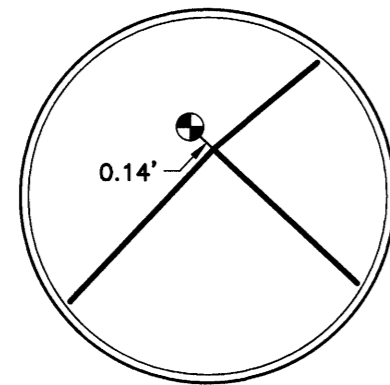

DETAIL Y
NOT TO SCALE

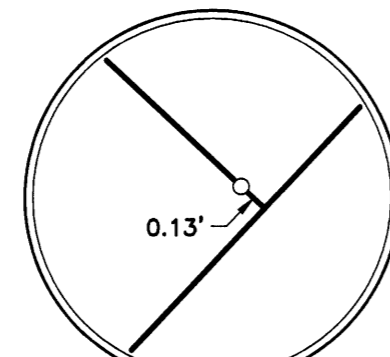

DETAIL Z
NOT TO SCALE

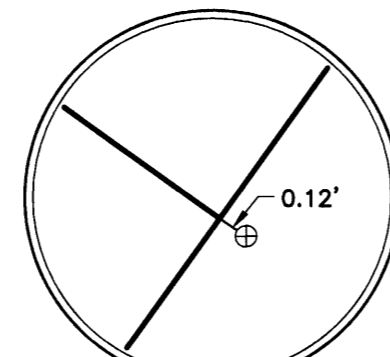

DETAIL AA
NOT TO SCALE

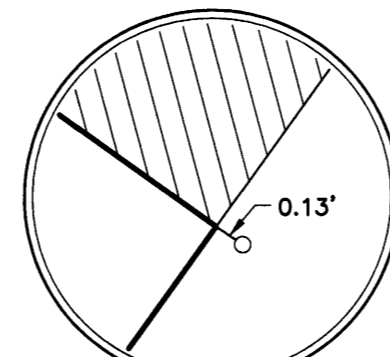

DETAIL BB
NOT TO SCALE

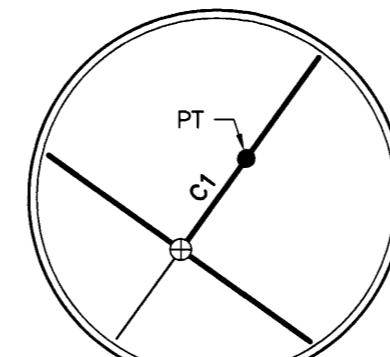

DETAIL CC
NOT TO SCALE

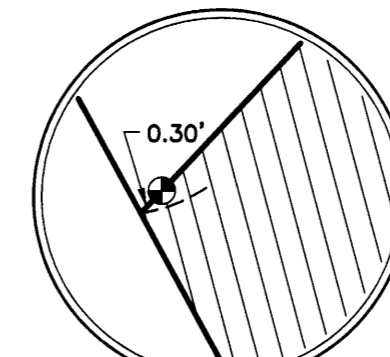

DETAIL DD
NOT TO SCALE

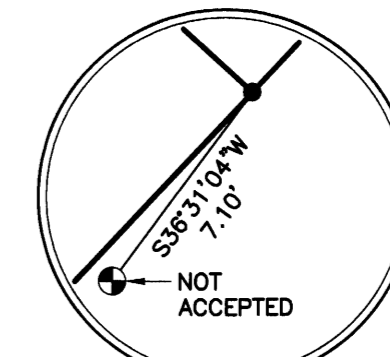

DETAIL EE
NOT TO SCALE

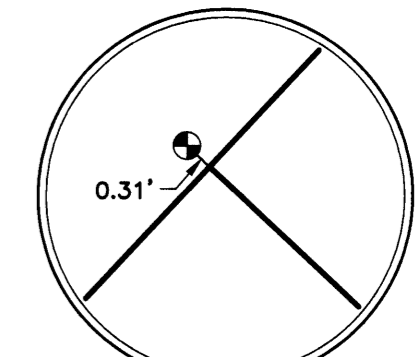

DETAIL FF
NOT TO SCALE

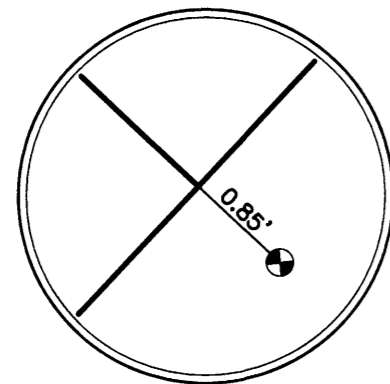

DETAIL GG
NOT TO SCALE

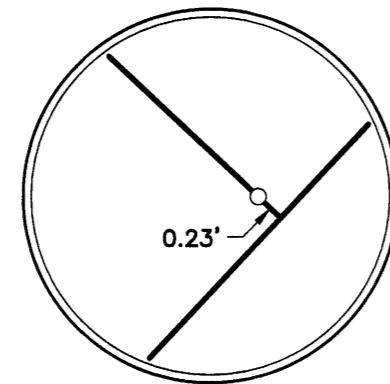

DETAIL HH
NOT TO SCALE

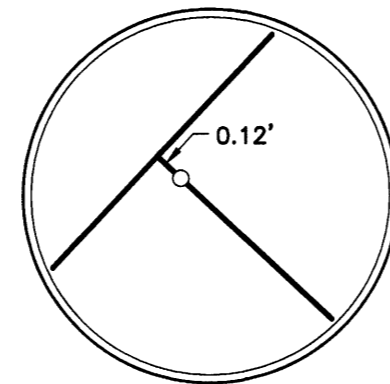

DETAIL II
NOT TO SCALE

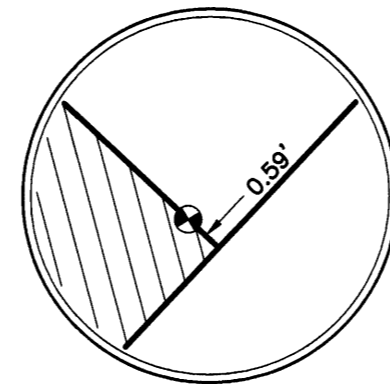

DETAIL JJ
NOT TO SCALE

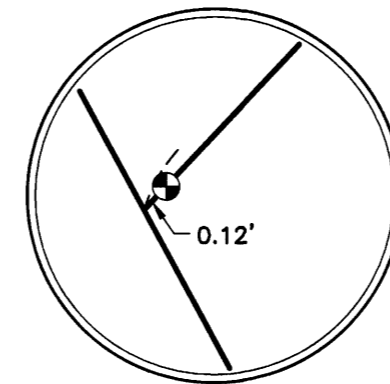

DETAIL KK
NOT TO SCALE

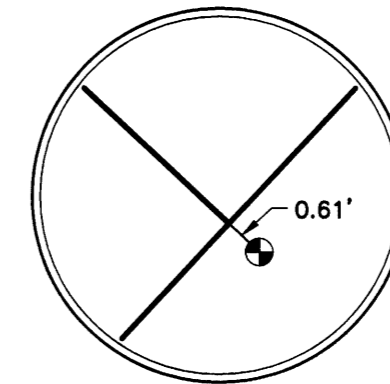

DETAIL LL
NOT TO SCALE

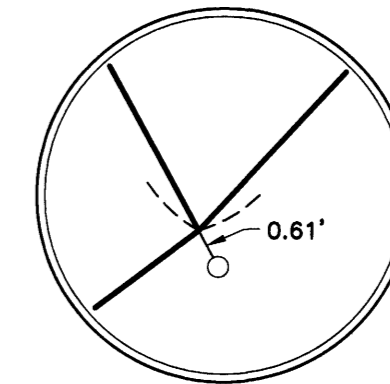

DETAIL MM
NOT TO SCALE

Jeremy Russell
Digitally signed on:
Nov 05, 2013



STATE SUBDIVISION—AMENDED PINECREST ADDITION			
A PORTION OF SECTION 32, TOWNSHIP 19 NORTH, RANGE 3 EAST, BOISE MERIDIAN, VALLEY COUNTY, IDAHO			
JUB		J-U-B ENGINEERS, Inc. 7825 Meadowlark Way Coeur d'Alene, Idaho 83815 Phone: 208.762.8787	
DWG NAME: 20-11-036_Amended Pinecrest Addition			
DR. DFG	CH. GJR / DRB	SHEET 6	OF 6
SCALE: NONE		DATE: November 2013	PROJ. NO.: 20-11-036